

GENSET MODEL

Model	P 251
Mechanical version	Open version with compact base frame and high capacity integrated fuel tank without collection basin.
Fuel Tank Capacity l.	520

RATED TECHNICAL DATA

Prime Power (PRP)	250.00 kVA
Prime Power (PRP)	200.00 kW
Emergency power (E.P.)	275.00 kVA
Emergency power (E.P.)	220.00 kW
Rated Power Factor (cosφ)	0.8
Windings	Three phases Series Star
Rated three-phase concatenated voltage	400 V
Rated phase-neutral voltage	230 V
Rated frequency	50 Hz
Fuel type	Diesel

DIMENSIONS AND NOISE

Length	2620 mm
Width	1120 mm
Height	1850 mm
Weight	2210 kg
Sound pressure 7 m.	- dBA

FUEL CONSUMPTION

Fuel Cons. at 100% (E.P.)	60.70 l/h
Fuel Cons. at 100% (P.R.P)	55.50 l/h
Fuel Cons. at 75% (P.R.P.)	41.60 l/h
Fuel Cons. at 50% (P.R.P.)	28.90 l/h
Fuel Cons. at 25% (P.R.P.)	0.00 l/h

GENERAL ALTERNATOR DATA

Alternator brand	STAMFORD
Alternator model	UCDI274K
P.R.P. Power	250.0 kVA
E.P. Power	275.0 kVA
Winding	Three phases Series Star
Terminals Number	12.00 nr.
IP Protection	23
Electronic regulator	AS440
Precision	± 1.00 %

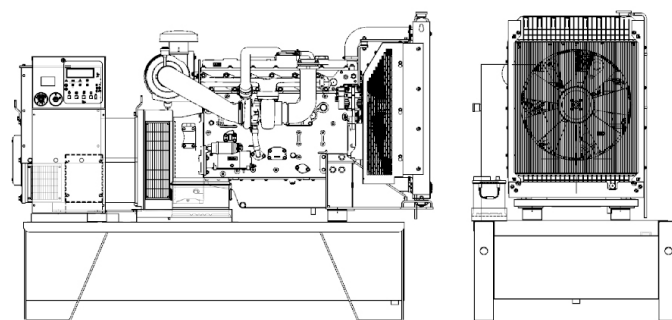

For illustrative purposes only

GENERAL ENGINE DATA

Engine brand	PERKINS
Engine model	1506A-E88TAG3
Cylinders	6
R.P.M.	1500
Cubic capacity	8.80
Air intake	Turbo
Standard voltage	24 Vdc
Sae	-
BMEP	2145 kPa
Cooling	Water
Flywheel P.R.P. Power	222 kW
Flywheel E.P. Power	244 kW
Electronic regulator	Standard
Precision class	G2
Oil quantity	41.00
Engine Antifreeze capacity	13.90
Radiator type	Tropicalized
Heat from radiator	147.00 kW
Heat from exhaust	170.00 kW
Heat from radiation	15.00 kW
Exhaust temperature	558 °C
Cooling air flow	370.00 m³/min
Combustion air flow	15.00 m³/min
Exhaust gas flow	40.40 m³/min
EU Stage	Not available

CONTROL PANELS

DSE4520



STANDARD REFERENCE CONDITIONS

Standard reference conditions temperature 25°C, altitude 100m asl, relative humidity 30%, atmospheric pressure 100 kPa (1 bar), power factor 0.8 lag, balanced load - non distortional. Fuel consumption is nominal and refers to specific weight 0,850kg/l. Sound power values refer to free field conditions: the installation site may influence the values. Dimensions, weights and other specifications contained in the technical data sheet and related attachments are nominal, subject to tolerances and refer to the model with standard equipment, any optional and additional equipment/accessories can modify weight, dimensions, performance. **P.R.P. Prime Power-Continuous power at variable load.** The power that a genset can supply in continuous service at a variable load for an unlimited number of hours per year while respecting the maintenance intervals established in the environmental conditions stated by the Manufacturer, according to ISO8528-1. The average power supplied over time and any applicable overload must be less than the percentages stated by the Manufacturer. **L.T.P. Limited-time running power-Limited power:** The maximum power that a genset can supply for a limited time respecting the maintenance intervals established in the environmental conditions stated by the Manufacturer according to ISO 8528-1. The number of hours per year is stated by the Manufacturer. Overload is not permitted. The data contained in this document is nominal and refers to the standard equipped model and is not binding. The manufacturer reserves the right to revise the information without notice per our policy of continuous product development and improvement. **E.P. - Emergency power:** This is the maximum power that a generating set can deliver for a limited number of hours per year while complying with the maintenance frequency stipulated under the environmental conditions set by the Manufacturer. The number of hours per year is determined by the engine manufacturer. The average power output over time must be lower than the percentages set by the engine manufacturer. Overloading is not allowed.